

A rotational encoder based hesitance exchanging engine control approach

K.S.B.Vara Prasad, HEMA ADARI,GNANANAND KODI

Assistant professor,
Department of EEE Engineering,
Visakha Institute of Engineering & Technology,
Division,GVMC,Narava, Visakhapatham, Andhra Pradesh.

Abstract. Switched Reluctance Motors (SRMs) are becoming more popular in electric drive development due to their advantages and environmental concerns. In terms of development, the SRM has a prominent position because to its ease of use, robustness and cheap cost. It is possible to use a sensorless approach to operate SRM, however this method is more complicated and has a greater number of limitations. Sensor-based rotor position detection, on the other hand, has several benefits, despite the fact that it requires hardware to be attached to the shaft. According to the findings of this study, digital signal controllers may be used to create a control strategy. A solution to the wide-range speed and stationary operating issues may be found in this approach. On-off times of switches may be adjusted through software as well. Simulators and tests were used to confirm the findings.

1. Introduction

Electrified drives play a major part in industrial applications. They used DC motors and AC induction motors in the past. BLDC and SRM motors are increasingly being used in electric drive systems due to significant advancements in power electronics and digital control.. Environmental concerns have sparked the development of electric vehicles and hybrid electric vehicles [1] and [2, respectively]. In spite of the fact that SRM's torque is less than BLDC's, the simplicity, durability, and cheap cost of SRM make it more intriguing than BLDC. The strategy consists of two stages, the first stage being used to calculate the initial pulse number, and the second stage being used as the SRM's principal controller.

In the sensorless concept, the rotor position may be determined without the need of any extra equipment. Low and high speed sensorless control implementation is difficult. It is possible to measure voltage and current without using any sensors at all, for example,

by monitoring the voltage and current caused by each other in an inactive phase

To pinpoint its exact position, an air gap sensor installed in the rotor of the motor might be employed [7]. To monitor the rotor's position, a Switched Reluctance Position sensor (SRP) may be attached to the motor's shaft [8]. [7] The SRM may be engaged by producing a high-frequency signal in order to emulate an inductive rotor position sensor. As a result of its unsaturated phase inductance, this motor may be used as a position sensor⁽¹⁾[9]. Optical sensors may be used to identify the relative locations of rotors and stators even while moving at high speeds. An analog encoder can keep the stator phase excitation and SRM position in sync while employing high-speed SRM detection. [11].

2. Reluctance Motor with a Switched Configuration

The rotor of a Switched Reluctance Motor (SRM) has no permanent magnets, and the stator is wound in a single phase only. SRM is shown in Figure 1 with a same circuit.

Fig. 1: A schematic showing how traction parameters are measured.

Saturation, leakage fluxes, and mutual inductance effects are ignored to make the analysis simpler, and the result is [12]:

$$\lambda(\vartheta, i)v = R \cdot i + e(\vartheta, i) = R \cdot i + \frac{d}{dt} \lambda(\vartheta, i)$$

where R=phase resistance, i=phase current, e=back EMF, θ = rotor position and λ =linkage. Power may be calculated by multiplying Eq. (1) by the current[4].

$$v \cdot i = R \cdot i^2 + i \cdot \frac{d\lambda(\vartheta, i)}{dt}$$

The ohmic dissipation is the first term on the right-hand side of the equation, whereas the mechanical current sum is the second term on the right-hand side of the equation [5].

As indicated in Fig. 2, a field's stored energy (W_f) and coenergy (W_c) may be expressed as follows:

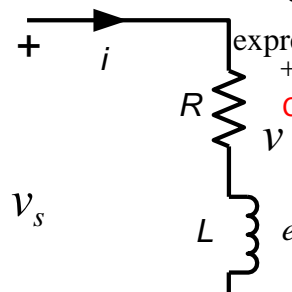

$$W_f = i(\vartheta, \lambda) \partial \lambda, \quad (6)$$

$$W_f = \lambda(\vartheta, i) \partial i. \quad (7)$$

3. Converter Topology

Three phase converters are needed to operate a four pole rotor (SRM6/4) and SRM with 3-phase stator windings. Some converter topologies may be utilized as an electric motor. A power circuit based on the $(n + 1)$ topology is shown in this study. This architecture contains four static switches and four diodes for a three-phase application (Fig. 3). It is possible to use this converter in one of three ways. SRM phase stator windings may be energized by using switch Q4 and lower side switch Q2 or Q3 (magnetizing mode). For an appropriate phase stator, positive torque is generated by its inductance profile slope. (see Fig. 4(a)).

This causes an increase in phase current.

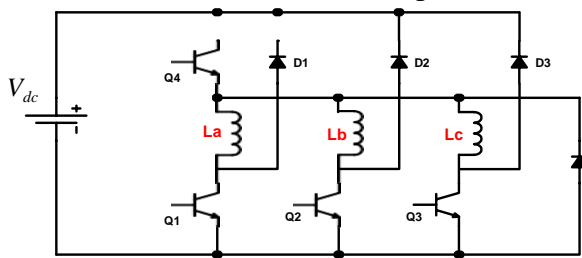
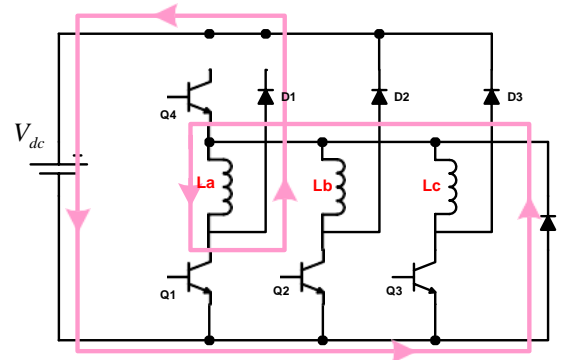

Fig.3: Topology of $(n+1)$ converter for 6/4 SRM.

(a) under In magnetizing mode, The converter



(a) In demagnetizing mode, the converter.

Fig.4: Topology of $(n+1)$ converter for 6/4 SRM.

There are two ways to cut off the active phase winding's current flow. The first method, demagnetizing, causes the stator winding to be linked to a source with the opposite polarity as the stator winding, which causes the current to drop quickly.

4. Results and Discussion

Following this research, computer simulations and tests were carried out in order to verify the findings. The power supply for the project was a $(n + 1)$ converter (depicted in Fig. 6). Simulations were run using PSIM using the settings listed in Table 1.

Tab. 1: For both simulation and experimentation, SRM parameters may be

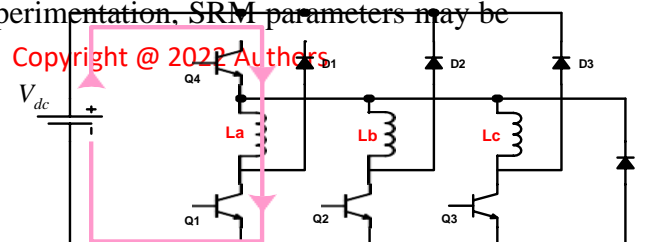

found

0.50hm	Resistance
1mH	Min.inductance
20degree	Min.InductanceAngle
6/4	Stator/RotorPole
3mH	Max.Inductance

For a given SRM speed, the drivetrain must be subjected to more torque. Stator winding current reaches its maximum value while running between "on = 0" and "off = 45," as soon as inductance profile begins to rise. (See Graph 13). A low speed is a consequence of a stream that is too big to flow beneath the negative slope of the Fig. 14.

In Fig. 23, it is possible to determine the rotational position by use of a 2000 PPR rotary encoder.. The controller's core is a 16-bit digital signal controller (dsPIC30F4012). When the rotary encoder delivers signals A and Z to the dsPIC, the dsPIC receives information

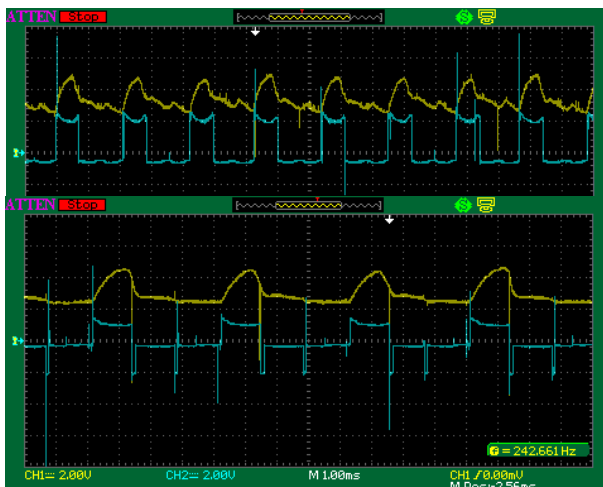

about the rotary encoder's pulses and a

reset signal for every revolution. Tab 1 displays the data needed to complete this assignment. Average torque is small because to the inductance curve.

Two figures depict the SRM testing in magnetizing and freewheeling modes.

Due to the fact that there is no voltage

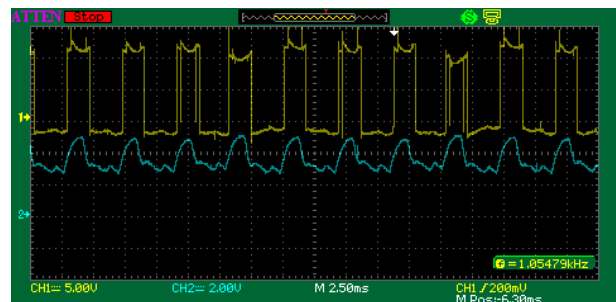

provided to the stator winding in these tests, the currents flowing through it tend to diminish slowly. (freewheeling mode).

Fig.23:The experimental model.

Fig. 24:In both magnetizing and freewheeling modes, the SRM drive yielded the following experimental results: (pulse number on: 0, pulse number off: 400).

Fig. 25:Test results of the SRM drive in magnetizing and freewheeling modes (a) phase current (b) phase voltage (c) (pulse number on: 0, pulse number off: 500).

Fig. 26: Findings from tests using the SRM drive in magnetizing and freewheeling modes (a) phase current (b) phase voltage 3846 RPM (pulse number θ_{on} : 0, pulsenum θ_{off} :500).

Conclusion

This article describes a control technique for driving an SRM motor using a rotary encoder to detect the rotor's location. The first stage determines the starting pulse number, while the second is the SRM's principal controller. By adjusting the angle at which switches are turned on and off, the suggested control technique may improve the torque output of the machine. Using simulations and tests, the suggested control technique may be shown to be successful, based on the outcomes.

References

1. EMADI, A., Y. J. LEE and K. RAJASHEKARA. Power Electronics and Motor Drives in Electric, Hybrid Electric, and Plug-In Hybrid Electric Vehicles. *IEEE Transactions on Industrial Electronics*. 2008, vol. 55, iss. 6, pp. 2237–2245. ISSN 1000-6644. DOI: 10.1109/TIE.2008.922768.
2. SHAO, J. An Improved Microcontroller-Based Sensorless Brushless DC (BLDC) Motor Drive for Automotive Applications. *IEEE Transactions on Industry Applications*. 2006, vol. 42, iss. 5, pp. 1216–1221. ISSN 0093-9994. DOI: 10.1109/TIA.2006.880888.
3. EHSANI, M. and B. FAHIMI. Elimination of Position Sensors in Switched Reluctance Motor Drives: State of the Art and Future Trends. *Transactions on Industrial Electronics*. 2002, vol. 49, iss. 1, pp. 40–47. ISSN 0278-0046. DOI: 10.1109/41.982246.
4. HUSAIN, I. and M. EHSANI. Rotor Position Sensing in Switched Reluctance Motor Drives by Measuring Mutually Induced Voltages. *IEEE Transactions on Industry Applications*. 1994, vol. 30, iss. 3, pp. 665–672. ISSN 0093-9994. DOI: 10.1109/28.293715.
5. XU, Z. Sensorless Switched Reluctance Motor Driver System Control by Detecting the Derivative of the Phase Current. In: *The 2011 International Conference on Electric Information and Control Engineering*. Wuhan: IEEE, 2011, pp. 1116–1119. ISBN 978-1-4244-8036-4. DOI: 10.1109/ICEICE.2011.5777929.
6. PANDA, D. and V. RAMANARAYAN. Sensorless Control of Switched Reluctance Motor Drive with Self-Measured Flux-Linked Characteristics. In: *The IEEE 31st Annual Power Electronics Specialists Conference*. Galway: IEEE, 2000, pp. 1596–1574. ISBN 0-7803-5692-6. DOI: 10.1109/PESC.2000.880539.
7. TRAORE, W. F. and R. A. MCCANN. Rotor Position Estimation in a Switched Reluctance Motor Using Embedded Magnetic Field Sensors. In: *The 2010 IEEE Power and Energy Society General Meeting*. Providence, RI: IEEE, 2010, pp. 1–11. ISBN 978-1-4244-6549-1. DOI: 10.1109/PES.2010.5590141.
8. CAI, J. and Z. DENG. Switched-

- Reluctance Position Sensor. *IEEE Transactions on Magnetics*. 2014, vol. 50, iss. 11, pp. 1–4. ISSN 1478-7148. DOI:10.1109/TMAG.2014.2329957.
9. CAI, J., Z. LIU, H. JIA, X. ZHAO and F. XU. An Inductive Position Sensor with Switched Reluctance Motor Structure. In: *The 20th International Conference on Electrical Machines and Systems (ICEMS)*. Sydney: IEEE, 2017, pp. 1–4. DOI:10.1109/ICEMS.2017.8056495.
10. GONG, C., T. HABETLER, J. RESTREPO, and B. SODERHOLM. Direct Position Control for Ultra-high Speed Switched Reluctance Machines Based on Non-contact Optical Sensors. In: *The 2017 IEEE Electric Machines and Drives Conference (IEMDC)*. Miami: IEEE, 2017, pp. 1–6. ISBN 978-1-5090-4281-4. DOI:10.1109/IEMDC.2017.8002289.
11. AHN, J. W., S. J. PARK and D. H. LEE. Novel Encoder for Switching Angle Control of SRM. *IEEE Transactions on Industrial Electronics*. 2006, vol. 53, no. 3, pp. 848–854. ISSN 0278-0046. DOI:10.1109/TIE.2006.874278.
12. DIRENZO, M. T. Application Report: SPRA420A. *Switched Reluctance Motor Control - Basic Operation and Example Using the TMS320F240*. Texas Instruments, 2000.